

Series 69

Standard Relief Valves for
Liquid Applications.



APPLICATIONS INCLUDE:

Engineered and designed for heavy-duty industrial usages.
Single piece bonnets with sealed hex-caps to minimize leakage.

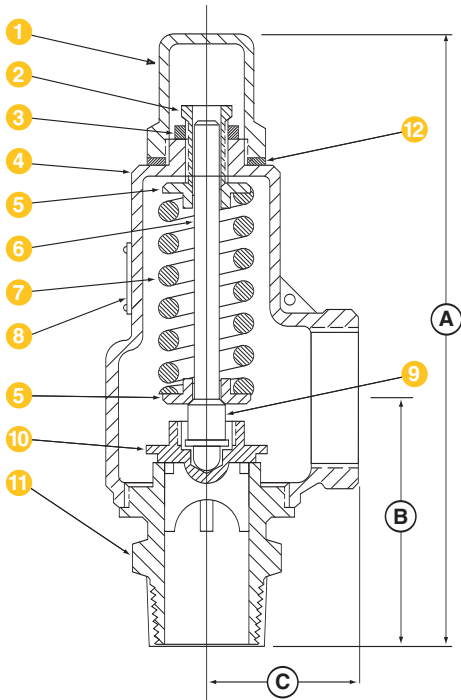

SIZES FROM 1/4" TO 3"
PRESSURE TO 750 PSIG
TEMPERATURES TO 450° F

PARTS IDENTIFICATION & MATERIALS		
ITEM	PART NAME	MATERIAL
1	HOOD	BRASS
2	PRESSURE SCREW	BRASS
3	LOCK NUT	BRASS
4	BONNET	BRONZE
5	SPRING PLATE	BRASS/STEEL*
6	SPRING POST	BRASS/STEEL*
7	SPRING	STAINLESS STEEL
8	NAME PLATE	ALUMINUM
9	SPRING PLATE SUPPORT	BRASS/STEEL*
10	DISC	BRONZE
11	BODY	BRASS/BRONZE
12	SEALING DISK	TEFLON

* STEEL PLATED

ORDERING/IDENTIFICATION	
SERIES	DESCRIPTION
69	BRASS/BRONZE SEATING (STD)
69-F	FEMALE INLET
69-H	HANDLE WHEEL

SERIES 69 DIMENSIONS • LIQUID								
PLEASE SPECIFY SERIES, SIZE, SERVICE AND SET PRESSURE.								
SERIES	VALVE SIZE	OUTLET SIZE	SEAT SIZE	-----DIMENSIONS-----			MAX. SET PRESSURE PSIG	WEIGHT LBS
				A	B	C		
69	1/2"	1/2"	1/2" - A	5 7/8	2 1/8	1 3/8	400	1.5
69	1/2"	3/4"	1/2" - A	5 7/8	2 1/8	1 3/8	400	1.5
69	3/4"	3/4"	3/4" - B	6	2 3/8	1 3/8	400	2
69	3/4"	1"	3/4" - B	6	2 3/8	1 3/8	400	2
69	1"	1"	1" - C	7 1/2	2 5/8	1 7/8	400	3
69	1"	1 1/4"	1" - C	7 1/2	2 5/8	1 7/8	400	3
69	1 1/4"	1 1/4"	1 1/4" - D	8 1/2	3 1/4	2	400	4.5
69	1 1/4"	1 1/2"	1 1/4" - D	8 1/2	3 1/2	2	400	4.5
69	1 1/2"	1 1/2"	1 1/2" - E	9 3/4	3 1/2	2 1/2	400	6.5
69	1 1/2"	2"	1 1/2"	9 3/4	3 1/2	2 1/2	400	6.5
69	2"	2"	2" - F	11 1/8	4	2 5/8	400	9.25
69	2"	2 1/2"	2" - F	11 1/8	4	2 5/8	400	9.25
69	2 1/2"	2 1/2"	2-1/2" - G	12	4 3/4	3 1/8	400	21
69	2 1/2"	3"	2 1/2" - G	12	4 3/4	3 1/8	400	22
69	3"	3"	3" - H	13 1/2	5 1/8	4 3/8	400	24

STANDARD VALVE FOR LIQUID RELIEF IS "SAME SIZED OUTLET" (UNLESS OTHERWISE SPECIFIED)
 STAINLESS STEEL TRIMMING RECOMMENDED FOR PRESSURE SETTINGS OVER 300 PSI (OR FOR CHEMICAL REACTIVE PURPOSES)
 2-1/2 & 3" MAX SET PRESSURE 350 PSI



SERIES 69 CAPACITIES

Liquid Capacity in Gallons Per Minute (GPM) at 25% Over Pressure • SIZES: 1/2"-3"

SET PRESSURE	A 1/2"	B 3/4"	C 1"	D 1 1/4"	E 1 1/2"	F 2"	G 2 1/2"	H 3"
5	3.9	7.7	12	17	22	33	44	55
10	5.6	8.1	17	24	31	46	62	78
15	6.8	13	21	29	38	56	76	95
20	7.9	15	24	34	44	65	88	111
25	8.8	17	27	38	49	73	98	124
30	9.7	19	29	41	53	80	107	136
40	11	22	34	48	62	92	124	157
50	12	24	38	53	69	103	139	175
60	13	26	42	58	75	112	151	190
75	15	30	47	65	85	126	170	214
100	18	34	54	76	98	146	196	248
125	20	38	60	85	109	163	219	277
150	22	42	66	93	120	178	240	303
175	23	45	71	100	129	193	259	328
200	25	48	76	107	138	206	277	350
225	26	51	80	113	146	218	293	371
250	28	54	85	120	154	230	310	392
275	29	56	89	125	161	240	325	410
300	31	59	93	131	169	252	340	429
325	32	61	97	136	176	262		
350	33	64	101	141	183	272		
375	34	66	104	146	189	281		
400	35	68	108	151	195	291		

LITERS PER MINUTE = GPM x 3.785 BAR = PSI x .06895

ABOVE 400 PSIG SET, CONTACT FACTORY



10195 Brecksville Road, Brecksville, OH 44141 USA • Telephone: +1.440.838.7690 • Fax: +1.440.838.7699 • E-mail: farris@curtisswright.com

Facilities: Brecksville, OH USA, Brantford, Ontario, Edmonton, Alberta, Canada, Kettering, Northants, UK, Delhi, India

Offices: worldwide. For a listing of our global sales network, visit our website at www.farrisengineering.com

While this information is presented in good faith and believed to be accurate, Curtiss-Wright Flow Control Corporation, Farris Engineering, does not guarantee satisfactory results from reliance on such information. Nothing contained herein is to be construed as a warranty or guarantee, expressed or implied, regarding the performance, merchantability, fitness or any other matter with respect to the products, nor as a recommendation to use any product or process in conflict with any patent. Curtiss-Wright Flow Control Corporation, Farris Engineering, reserves the right, without notice, to alter or improve the designs or specifications of the products described herein. Valves are manufactured, assembled, set and tested by Aquatrol, Inc.