

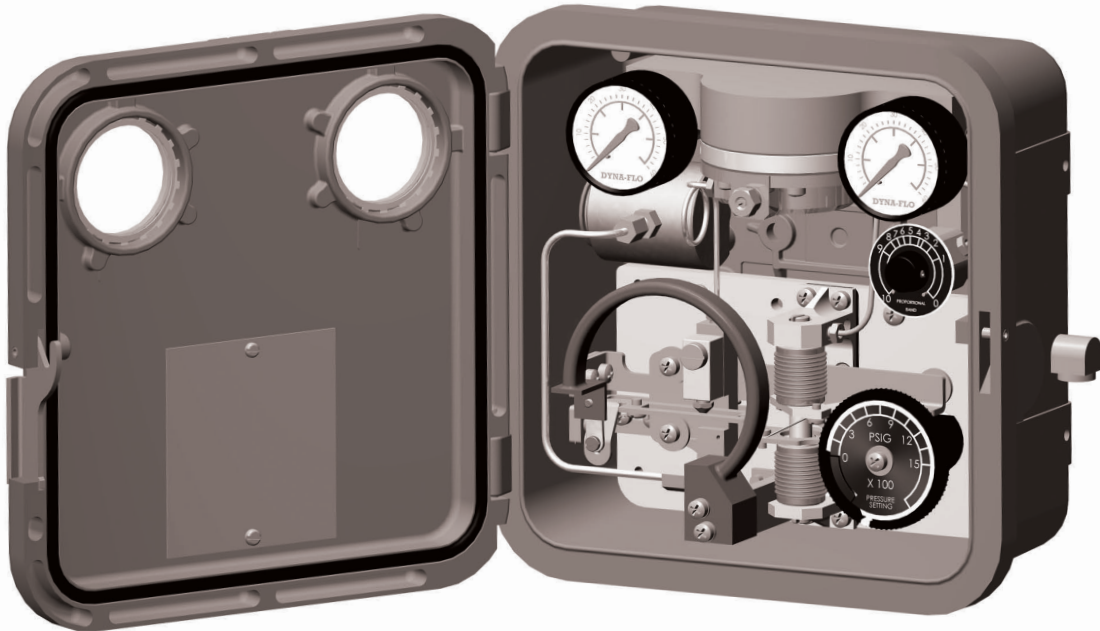

Instruction Manual October 2005

Model
4000 Control Valve
Operation, Parts and Instruction Manuals



Dyna-Flo 4000

Operation, Parts and Instruction Manual

Table of Contents

Calibration	2
Adjustments	4
Maintenance	5
Changing Action	6
Relay Manifold	8
Output Signal	9
Start-Up & Tuning	11
Parts	12
Kits	12
Detailed	15



Model **4000** Pressure Controller Operation, Parts and Instruction Manuals

!NOTICE!

These instructions are meant to be used with the Dyna-Flo 4000 Series Technical Bulletin as they refer to Figures and Tables therein. If you do not have the Technical Bulletin, contact Dyna-Flo immediately, or visit www.dynaflo.com

Each controller is factory checked. Check the calibration for the specific application, before a controller is put into service.

Calibration Procedure Initial Set-up

The 4020 Differential Gap Instructions are at the end of this section

- 1** It is recommended to calibrate the controller in the position in which it will be operated.
 - 2** Determine supply pressure requirement by checking controller output signal range:
 - a) An output signal range of 6-30 psi (40-200 KPa) would require 35 psi (240 KPa) supply pressure.
 - b) An output signal range of 3-15 psi (20-100 KPa) would require 20 psi (140 KPa) supply pressure.
 - 3** Connect a supply pressure line at the required setting, to the SUPPLY connection at the back of the case as shown in figure 12.
 - 4** Install 1/4" NPT pipe plug at the OUTPUT connection at the back of the case as shown in figure 5. The controller output pressure change is measured by the output pressure gauge.
 - 5** Locate a pressure supply (of compressed air or nitrogen) equivalent to the bourdon tube rating.
 - 6** With the block valve closed, connect the pressure supply through a block valve and regulator to the CONTROL pressure block.
- ! NOTE !** _____
- There are 2 possible connections to the control pressure block:
- a) The CONTROL connection in the back of the case
 - b) The connection at the left side of the case.
- 7** Plug the unused connection.
- 7** Verify that the calibration adjuster screws (Figure 5, Key 44) are at mid-point in the calibration adjuster (Figure 5, Key 8).
- 8** Inspect the following for leaks (using leak detection solution or soapy water).
- 4000 / 4020 Controller**
Relay Manifold
All tubing and connections (relay & compensator)
Bellows, bellows frame and bellows screws
Proportional band and elbow fitting
- 4010 Controller**
Relay Manifold
All tubing and connections (relay & compensator)
Bellows, bellows frame and bellows screws
Proportional band and elbow fitting
Reset restrictor valve
Reset and compensator tubing
- 9** Set PRESSURE SETTING knob (Figure 4) at 0 (zero) setting.
- 10** Adjust the nozzle (Figure 5, Key 50), until the output pressure is between 8 and 10 psi.
- 4000 Controller**
A) Rotate proportional band knob and set at zero (closed position).



Model **4000** Control Valve Operation, Parts and Instruction Manuals

Calibration Procedure Initial Set-up (cont'd)

4000 Controller (cont'd)

The output pressure gauge should indicate full supply pressure.

Check that for a direct acting unit the bellows movement is downward, and upward for a reverse acting controller.

- B** Rotate proportional band knob and set at 10 (open position).

The output pressure gauge should indicate 0 - 5 psi pressure.

Check that for a direct acting unit the bellows movement is downward, and upward for a reverse acting controller.

- C** Rotate proportional band knob and set at 1.5 (15% proportional band).

The output pressure gauge should indicate 8-10 psi pressure.

4010 Controller

Refer to Figure 6.

Rotate Reset Restrictor Valve and set at MAX.

! Note !

If the 4010 is to be left at the maximum Reset setting, the 4010 controller will perform as a 4000 (proportional band) controller. It is recommended that the reset bellows tubing be removed and retubed as shown in Figure 7 for a 4000 (proportional band) controller.

Range

4000 Controller

Verify that the proportional band is set at 1.5.

4010 Controller

Additionally, verify that the reset valve is set at 0.01 minutes per repeat.

- A** Apply input pressure equal to the bourdon tube maximum rating.
- B** Rotate pressure setting knob (Figure 4) to the maximum value which is equal to the bourdon tube rating.
- C** Output gauge reading should be between 8 and 10 psi. If not, adjust controller span by loosening one of the two calibration adjuster screws (Figure 5, Key 44) and move the calibration adjuster (Figure 5, Key 8) a small distance as explained below and illustrated in Figure 5.

For direct-acting controller

- a) *If output is below 8 to 10 psi, move calibration adjuster to the left.*
- b) *If output is above 8 to 10 psi, move calibration adjuster to the right.*

For reverse-acting controller

- a) *If output is below 8 to 10 psi, move calibration adjuster to the right.*
- b) *If output is above 8 to 10 psi, move calibration adjuster to the left.*

- D** Repeat calibration adjuster movements until output gauge reads between 8 and 10 psi on both zero and maximum value. (Maximum value is bourdon tube upper limit.)
- E** Isolate the controller from process, control, and supply pressure.
- F** Vent any trapped pressure from the controller.

4020 Controller

- A** Temporarily set-up the 4020 (differential gap) controller as a 4000 (proportional band) controller, by changing the proportional band tubing connection to the bellows frame. The reversing block IS NOT inverted at this time.



Model 4000 Pressure Controller Operation, Parts and Instruction Manuals

Calibration Procedure Initial Set-up (cont'd)

4020 Controller (cont'd)

- B** Calibrate as a 4000 (proportional band) controller.
- C** After calibration, restore the proportional band tubing to it's original connection on the bellows frame.
- D** Due to physical differences in the bellows, there may be a slight shift in the output pressure. This will be adjusted out through nozzle adjustments described below.
- E** Set the proportional band knob for the required differential gap (See adjustment section for differential gap details).
- F** Set the process pressure:

Direct Acting Controller

1 Move the pressure setting to the upper switch point value at which the output pressure will go from zero, to full supply pressure, with rising process pressure.

2 Apply input pressure to the bourdon tube, as you observe the output gauge. When the upper switch point value is reached, while increasing input pressure, the controller output should switch from zero pressure, to full supply pressure.

3 Adjust the nozzle to correct any upper switch point error, and retest until the switch point and input pressure values agree.

Reverse Acting Controller

The controller output described above will be reversed.

- G** Check controller operation by running the input pressure from zero to above the upper switch point, and observing the switching points. Set a new differential gap, vary the input pressure, and then repeat with the calibration settings.

Adjustments

Manual Set Point (4000 / 4010 / 4020)

Adjust the pressure setting by turning the pressure setting knob (Figure 4) to the desired pressure. This represents the upper switch point for a direct acting 4020.

Proportional Band (4000 and 4010)

To adjust the proportional band, rotate the proportional band knob (Figure 4) to the desired value (between 3 to 100%). This represents 3-100% of the sensing element range, and controls the percentage of sensed pressure change required to cause full output of the controller.

Differential Gap (4020)

Adjust the proportional band knob (Figure 4) to set the width of the differential gap about the switch point. Use Table 1 as a guide. Calculate the Differential Gap as follows:

$$\frac{(\text{Upper Switch Point} - \text{Lower Switch Point}) \times 100}{\text{Boudon Tube Range}}$$

Proportional Band Setting	Differential Gap (% OF Element Range)
1.2	10
1.8	20
2.5	30
3.1	40
3.8	50
4.4	60
5.1	70
5.7	80
6.4	90
7	100

Table 1 - Differential Gap Setting Guide

Reset (4010 only)

To adjust the reset action, rotate the reset knob (Figure 6) counter-clockwise to increase the speed. The minutes per repeat indicate the time required for the reset bellows pressure to equal the proportional bellows pressure.



Model **4000** Control Valve Operation, Parts and Instruction Manuals

! WARNING ! The following maintenance procedures require taking the controller out of service. To avoid personnel injury, only qualified technicians should perform the following procedures. Always ensure the controller is fully released of pressure or process fluid before starting maintenance.

Controller Maintenance

Regular Maintenance

- A** If the installation includes a supply regulator, periodically open the drain on the filter regulator to drain accumulated moisture.
- B** Push the cleaner wire on the relay orifice (key 83, Figure 3) to release moisture or particulate.
- C** Inspect, and if necessary, clean the opening of the vent assembly (Key 71, Figure 4) or the remote vent pipe, if one is used.
- A** Disconnect the control tubing (Figure 4, Key 14) at the bourdon tube end.
- B** Remove the screw (Key 11) that connects the link (Key 12) to the beam (Key 1).
- C** Unscrew two screws (Key 38) and washers (Key 35), and remove the bourdon tube (Key 7).
- D** Remove the screw (Key 11) that retains the link (Key 12) and link bearing (Key 34) to the bourdon tube (Key 7).

Replacing Gauges

Refer to Figure 4.

- A** Quantity 2 gauges (key 31) are used, one for output and one for supply pressure.
- B** Always ensure to check the range of the controller before ordering replacement gauges (0-30 psi gauges WILL NOT work on a 6-30 psi controller).
- C** Always use approved thread sealant on the threaded connections.
- E** Attach the link and bearing to the replacement bourdon tube.
- F** Attach the bourdon tube (Key 7) with two machine screws (Key 38) and washers (Key 35).
- G** Connect the link and bearing to the beam (Key 1).
- H** Check to be sure that the beam is reasonably parallel with the bottom of the case. The link (Key 12) should be in tension. If the beam is not parallel with the case, loosen the machine screws (Key 38), reposition the bourdon tube to get the beam parallel, and retighten the screws.

Replacing Bourdon Tube

Refer to Figures 4 & 5.

! WARNING !

Isolate the process sensing line prior to disconnecting the bourdon tube from the control tubing (Key 14). Be aware of potential hazards from disconnecting process connections.

! NOTE !

If a bourdon tube with a different range was installed, install a new dial having an adjustment range corresponding to the range of the bourdon tube. Remove the machine screws and washer (Key 19 and 72) and dial (Key 20).



Model **4000** Pressure Controller Operation, Parts and Instruction Manuals

! WARNING ! The following maintenance procedures require taking the controller out of service. To avoid personnel injury, only qualified technicians should perform the following procedures. Always ensure the controller is fully released of pressure or process fluid before starting maintenance.

Controller Maintenance

(cont'd)

- I** Check all tubing connections and the bourdon tube machine screws for leaks, tighten as necessary.
- J** Perform the calibration procedure.

Changing Proportional Valve

- A** Disconnect the tubing and remove the proportional band valve assembly (Figure 4, Key 55) from the elbow fitting (Key 11) by turning it counter-clockwise.
- B** Install the desired replacement assembly - **Do not over torque.**
- C** Use a proper thread sealant when reinstalling the tubing.
- D** Check for leaks.

Changing Reset Valve

- A** Disconnect the tubing and remove the reset restriction valve assembly (Figure 6) by removing a retaining screw (not shown) on the back of the controller.
- B** Install the desired replacement assembly.
- C** Use a proper thread sealant when reinstalling the tubing.
- D** Connect the tubing.
- E** Check all connections for leaks.
- F** Perform the calibration procedure.

Changing Action

Isolate the controller from process, control, and supply pressure. Vent any trapped pressure from the controller before proceeding.

Refer to Figure 2.

Direct to Reverse Action

Direct action

Increasing sensed pressure produces increasing output pressure

Reverse action

Increasing sensed pressure produces decreasing output pressure.

- A** Refer to Figure 2, and locate the new tubing and reversing block positions for the action desired.
- B** Changing the action is accomplished by reversing the position of 2 components:
 - 1) *the reversing block*
 - 2) *the bellows tubing*
- C** In the controller, locate the two bellows and the reversing block (Key 63, Figure 2).

For a 4000 (proportional-only) controller

Disconnect the proportional tubing (Key 10) from the bellows frame and reconnect it in the opposite hole.

For a 4010 (proportional-plus-reset) controller

Disconnect the proportional tubing (Key 10) and reset tubing from the bellows frame, and reconnect them in the opposite hole.

For both Models of Controllers

- A** Remove the reversing block screw (Key 66, Figure 2) and reversing block assembly (Key 63).



Model 4000 Control Valve Operation, Parts and Instruction Manuals

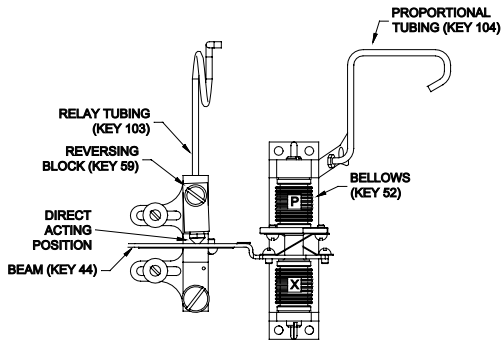

Direct Acting

MODEL 4000 Proportional-Only Controller

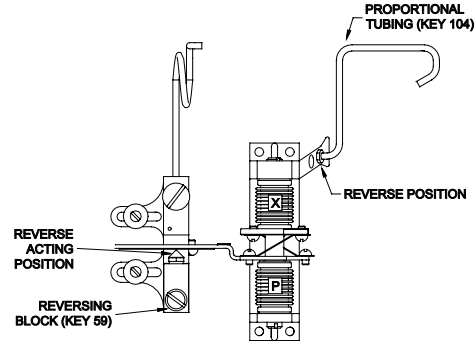

Reverse Acting

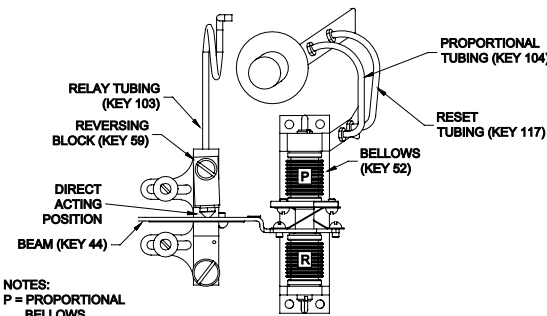

NOTES:
P = PROPORTIONAL BELLOWS
R = RESET BELLOWS
X = NO PRESSURE

Direct Acting

MODEL 4000 Proportional-Plus Reset Controller

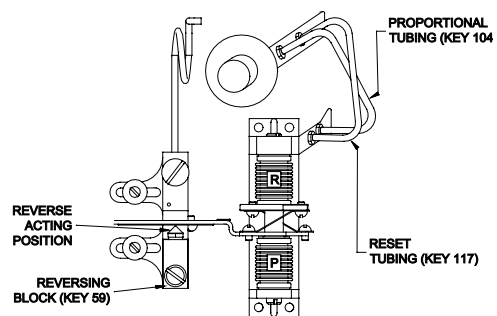

Reverse Acting

Figure 2 Tubing Connections

For both Models of Controllers (cont'd)

- B** Inspect the o-rings (Key 53) located in the recessed area under the reversing block screw head and between the reversing block assembly and the calibration adjuster (Key 8, Figure 5). Replace these o-rings, if necessary.
- C** Position the reversing block assembly, with o-ring, on the calibration adjuster so that the nozzle is on the opposite side of the beam (Key 1, Figure 2) from which it was removed. Properly position the reversing block assembly so that the alignment pin engages the hole in the calibration adjuster. Install the reversing block screw (Key 66) with o-ring (Key 53).
- D** Install the sealing screw with o-ring in the hole previously covered by the reversing block assembly.
- E** Install the relay tubing (Key 58) in the reversing block (Key 62).
- F** Check all the connections for leaks with leak detector solution
- G** Perform the calibration procedure.



Model **4000** Pressure Controller Operation, Parts and Instruction Manuals

Relay Manifold

Replacement

Refer to Figure 4.

- A** Always shut down the supply, control and process pressure line to the controller.
- B** Disconnect the relay tubing (Key 58) from the relay manifold (Key 56).
- C** Remove the relay manifold (Key 56) from the case by unscrewing the 2 retaining screws (Key 39 - not shown) on the back of the case.
- D** Remove the gauges, proportional band, and elbow fitting from the manifold. Install the gauges, proportional band, and elbow fitting into the new replacement manifold.
- E** Replace the relay manifold o-rings (Key 57). Place the o-rings on the inlet and outlet fittings on the relay manifold. With the manifold in place, insert and fasten the 2 screws (Key 39 - not shown) from the backside of the case.
- F** Connect the tubing, and check all connections for leaks.
- G** Perform calibration procedure.
- E** Inspect the valve seats (under a good light) for roughness due to corrosion. One seat is located in the diaphragm assembly (Key 75), and the other seat is located on the seat ring (Key 85), which is found in the relay manifold (Key 81). Replace the diaphragm assembly or seat ring if seats are damaged or worn.
- F** To install a replacement seat ring (Key 85) in the relay manifold, remove the 3 screws (Key 77) and washers (Key 80) retaining the seat ring. Remove the seat ring (Key 85), and o-ring (Key 74) from the seat pocket in the relay manifold.
- G** Inspect diaphragms and gaskets, and replace them if necessary.
- H** Replace the spring and valve plug if they show signs of corrosion.
- I** The lower diaphragm is part of the diaphragm assembly and must be replaced as an assembly.
- J** Clean all parts thoroughly before re-assembling.

Relay Reconditioning

Refer to Figure 3.

Disassembly

- A** Complete steps A through D of relay manifold replacement.
- B** Unscrew the orifice assembly (Key 83). Remove the o-rings (Key 79) from the orifice assembly.
- C** Place the relay manifold on the work surface with the casing screws facing up. Remove the casing screws (Key 78), in a criss-cross pattern.
- D** Remove and separate the lower casing (Key 76) bottom diaphragm (Key 86), spacer ring (Key 84), diaphragm assembly (Key 75), relay spring (Key 82), and valve plug spring (Key 88) from the relay manifold (Key 81).
- A** With the opening in the relay manifold facing up, place the valve plug spring in the bottom of the manifold. Carefully place the valve plug on top of the spring, such that the plug is pointing up.
- B** Install the seat o-ring in the pocket of the relay manifold. Carefully place the seat ring on top of the o-ring, ensuring the plug is sticking through the seat ring.
- C** With the seat ring in place, install the 3 screws and washers that retain the seat ring.



Model
4000 Control Valve
 Operation, Parts and Instruction Manuals

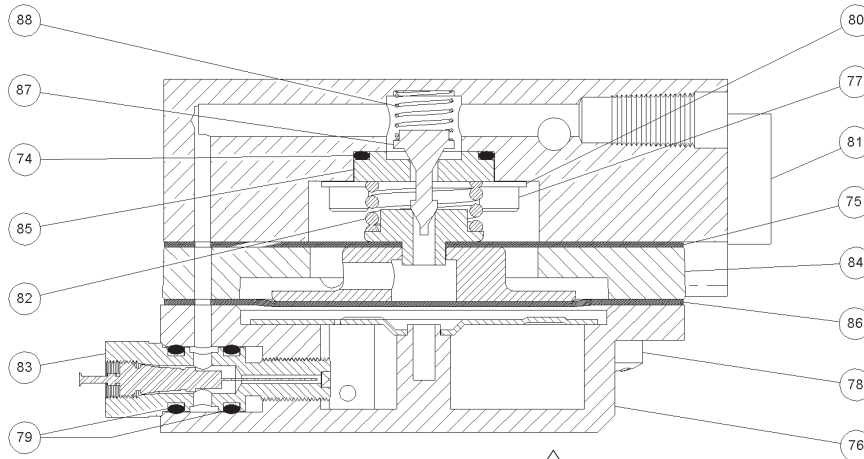

Figure 3 Relay Manifold Cross-Section

Relay Manifold
 (cont'd)

Re-assembly (cont'd)

- D** Place on the relay manifold, in order, the relay spring, diaphragm assembly, spacer ring and the top diaphragm. Ensure all the flow passage holes are lined up.
- E** Once the assembly of all these components is complete, the diaphragm casing can then be installed. Place the diaphragm casing on top of the relay manifold, taking care to maintain the alignment of the flow passages. A second check is to align the grooves on the casing and spacer ring, with the mark stamped on the relay manifold.
- F** Install the casing screws, but do not tighten them. Once they are all in, tighten in a criss-cross pattern.
- G** Install the o-ring (Key 79) on the orifice assembly (Key 83), and install the orifice assembly into the diaphragm casing.
- H** Replace the relay manifold o-rings (Key 57). Place the o-rings on the inlet & outlet fittings on the relay manifold. With the manifold in place, insert and fasten the 2 screws (Key 39 not shown) from the backside of the case.

- I** Install the elbow fitting (Key 11), proportional band (Key 55), gauges (Key 31), and tubing (Key 58). Check all connections for leaks.
- J** Perform the calibration procedure.

Changing Output Signal Range

From 3 to 15 psig (20 to 100 kpag) to a 6-30 psig (40 to 200 psig) output signal range or vice versa.

- A** Always shut down the supply, control and process pressure line to the controller.
- B** Refer to the parts list to make sure you have the bellows in appropriate range and material. Quantity: 2 required.
- C** Disconnect the tubing (Key 58) from the relay (Key 56) to the reversing block (Key 63, Figure 2), at the relay end.



Model
4000 Pressure Controller
Operation, Parts and Instruction Manuals

Changing Output Signal Range (cont'd)

- D** Disconnect the tubing from the bellows frame (Figure 5, Key 2) to the proportional band assembly, at the bellows frame end. (Bending of the tubing will be reduced if you loosen the fitting at the proportional valve end as well).
- E** Disconnect the tubing (Figure 4, Key 14) from the CONTROL pressure block (Figure 4, Key 13) to the bourdon tube (Key 7), at the CONTROL pressure block end.
- F** Remove the 4 machine screws (Key 40, Figure 4), and lift the controller subassembly from the case.
- G** Remove the screw (Key 11, Figure 5) that connects the link (Key 12) to the beam (Key 1).
- H** Unscrew two screws (Key 38) and washers (Key 35), and remove the bourdon tube (Key 7).
- I** Remove the screw (Key 11) that retains the link (Key 12) and bearing (Key 34) to the bourdon tube.
-
- J** Unscrew The bellows so that the end of the bellows and beam can be removed from the end of the bellows frame (Key 2).
- K** Compress the feedback bellows so that the end of the bellows and beam can be removed from the end of the bellows frame (Key 2).
- L** While firmly holding the bottom feedback bellows (Key 22) in your hand, turn the upper bellows counter clockwise with your other hand to separate the bellows from the beam assembly.
- M** Remove the bellows connecting stud (not shown) for re-use with the new bellows.
- N** With the stud that connects the two bellows in place in the spacer (Key 69), screw the new bellows onto the stud. Install new gaskets (Key 3) on each bellows.
- O** Compress the feedback bellows, and install them into the bellows frame (Key 2).
- P** With the beam parallel with the mounting base, secure the feedback bellows with the bellows screws (Key 23).
- Q** When tightening the bellows screws, make sure that the nozzle (Key 50) is centered on the flapper (Key 23).
- R** Install the bourdon tube if it was removed - Refer to the Replacing Bourdon Tube section.
- S** Replace the subassembly in the case and secure with the machine screws (Key 40, Figure 4).
- T** Reconnect all tubing. Take care to get the proportional tubing back in the right connection on the proportional valve (Refer to Figure 2).
- U** Unscrew tyhe supply and output gauges (Key 31, Figure 4) and install new gauges with correct ranges.
- V** Check all tubing connections and teh bellows screws (Key 4) for leaks. Tighten as necessary.
- W** Perform the calibration procedure.
-
- ! NOTE !** _____
Use Proper Thread Sealant on all tubing connections.
-



Model **4000** Control Valve Operation, Parts and Instruction Manuals

Start-Up & Tuning Guidelines

4000

- 1 Check that controller is calibrated.
- 2 Check that supply regulator set point matches the controller output range.
- 3 Set the pressure setting knob at the required pressure.
- 4 Based on your process (fast, or slow) set the proportional band:

a) for a fast (liquid) system, use a setting of 10 (100 percent)

b) For slow (gas) system uses a calculated proportional band setting, from the expression:

$$\frac{20 \times \text{Allowable Error}}{\text{Output Pressure Range}} \\ (\times 10 \text{ for percent value})$$

Example:

- 3 psig Allowable Error
- 30 psig Output Range
- $20 \times 3 / 30 = \text{setting of } 2 \text{ (20\% PB)}$

- 5 Check the proportional action by either making a small set point change, or bumping the flapper lightly, and watching for the output to cycle. Lower the proportional band setting if the system does not cycle, and check again. Repeat this process until the controller output does cycle, and then double proportional band setting for a reasonable starting point.
- 6 Minimize proportional band effect on set point by turning the nozzle (Key 50) until the process pressure matches the controller pressure setting.
- 7 Check the proportional band setting for stable operation by making a change in the process and watching for cycling.

4010

- 1 Check that controller is calibrated.
- 2 Check that supply regulator set point matches the controller output range.
- 3 Set the pressure setting knob at the required pressure.
- 4 Based on your process (fast, or slow) set the reset:

a) for a fast (liquid) system use 0.05 minutes per repeat

b) for a slow (gas) system use 0.5 minutes per repeat

- 5 Based on your process (fast, or slow) set the proportional band:

a) for a fast (liquid) system, use a setting of 10 (100 percent)

b) for slow (gas) system uses a calculated proportional band setting, from the expression:

$$\frac{20 \times \text{Allowable Error}}{\text{Output Pressure Range}} \\ (\times 10 \text{ for percent value})$$

Example:

- 3 psig Allowable Error
- 30 psig Output Range
- $20 \times 3 / 30 = \text{setting of } 2 \text{ (20\% PB)}$

- 6 Check the proportional action by either making a small set point change, or bumping the flapper lightly, and watching for the output to cycle. Lower the proportional band setting if the system does not cycle, and check again. Repeat this process until the controller output does cycle, and then double proportional band setting for a reasonable starting point.
- 7 Check the reset action by either making a small set point change, or bumping the flapper lightly, and watching for the output to cycle. Increase the reset setting if the system does not cycle, and check again. Repeat this process until the controller output does cycle, and then triple that reset setting for a reasonable starting point.
- 8 Check the reset setting for stable operation by making a change in the process and watching for cycling.



Model
4000 Pressure Controller
 Operation, Parts and Instruction Manuals

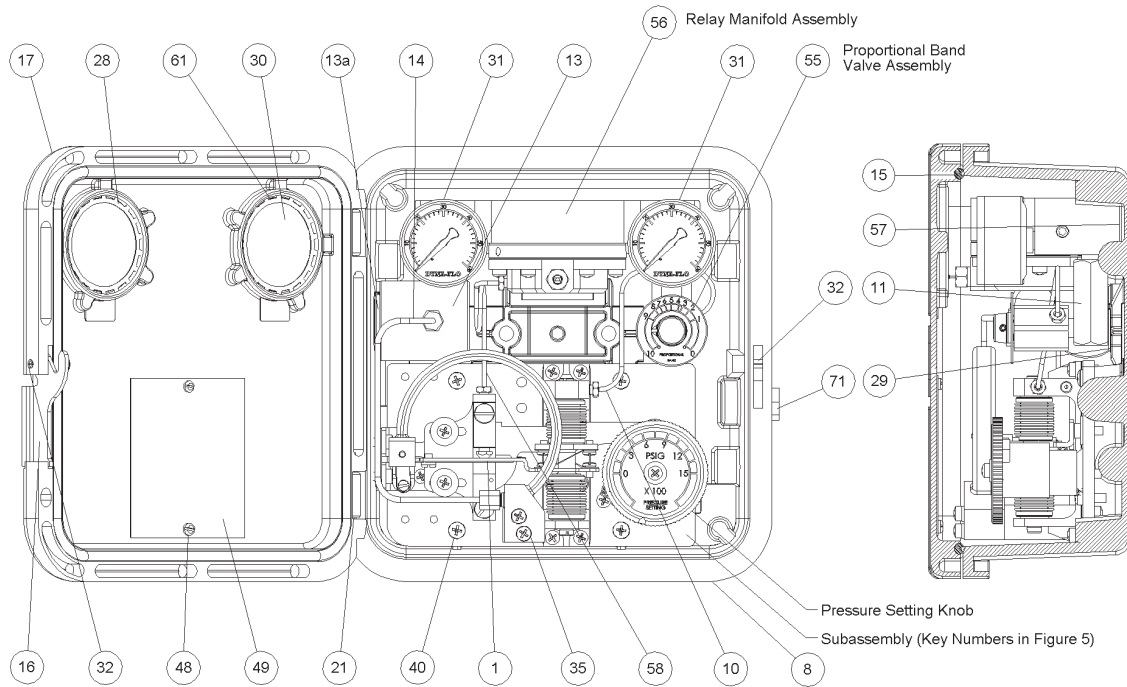

Figure 4 Dyna-Flo Model 4000 General Detail

Parts Ordering

Whenever corresponding with Dyna-Flo about a 4000 series pressure controller, refer to the nameplate (Key 48, Figure 4) for the serial number of the unit. Please order by the complete part number (as given in the following parts list) of each part required.

Controller Repair Kit R4000X00L1D

Kit contains Keys 3, 12, 13a, 15, 23, 27, 28, 29, 34, 37, 49, 50, 51, 57, 62, 63, 66, and 68

Relay Repair Kit RRELAYX0L1D

Kit contains Keys 73, 74, 75, 76, 79, 82, 83, 86, 87, and 88
 kit also includes part numbers:

1H2690301D - Gasket, Spring Plate, neoprene (not shown)

1C89740301D - Gasket, Relay Mount, neoprene (not shown)

Assemblies

	Number
Proportional Band Valve Assembly	10A9122X03D
Reset Restriction Valve Assembly	19A4361X01D



Model
4000 Control Valve
 Operation, Parts and Instruction Manuals

Parts

Key Description	Part Number		
1 Beam, steel	1H26682507D	0-3000 psig	16A7662X09D
2 Bellows Frame, aluminum	2H26530801D	0-5000 psig	16A7662X10D
3* Bellows Gasket, neoprene (2req'd)	2D39700301D	0-8000 psig	16A7662X11D
4 Bellows Screw (2 req'd)	1D39761402D	0-10000 psig	16A7662X12D
5 Bellows Stud, sst (not shown)	1H2658X001D	21 Door Latch Pin, steel pl (2 req'd)	PC00000003D
6 Bourdon Tube Bracket	PC00000025D	22 Feedback Bellows	
7* Bourdon Tube, sst		Brass	
0-30 psig	10B2892X01D	3-15 psig (20-100 kpag) (2 req'd)	14A5726X01D
0-60 psig	10B2892X02D	6-30 psig (40-200 kpag) (2 req'd)	14A5726X03D
0-100 psig	10B2892X03D	23 Flapper, sst	1H26694113D
0-200 psig	10B2892X04D	24 Flexure Strip Base, steel	1C89772508D
0-300 psig	10B2892X05D	25 Flexure Strip Washer, steel pl (2 req'd)	16A7671X01D
0-600 psig	10B2892X06D	26 Flexure Strip, sst	1C89783601D
0-1000 psig	10B2892X07D	27* Gasket, Bellows Frame (not shown), neoprene	1H26540301D
0-1500 psig	10B2892X08D	28* Gasket, Gauge Glass, neoprene (2 req'd)	0T01910408D
0-3000 psig	10B2892X09D	29* Gasket, Pressure Block, neoprene (not shown)	1C32860301D
0-5000 psig	10B2892X10D	30 Gauge Glass (2 req'd)	PC00000039D
0-8000 psig	10B2892X11D	31 Gauge, Supply and Output Pressure (2 req'd)	
0-10000 psig	10B2892X12D	0-30 psig	PC00000037D
8 Calibration Adjuster, steel pl	2H26624401D	0-60 psig	PC00000038D
9 Case, aluminum	PC00000010D	32 Latch Roll Pin, steel pl	PC00000003D
10 Proportional Tubing Assembly, sst		33 Knob Spring, steel pl (not shown)	1C22152702D
4000	1H6864000AD	34 Link Bearing Srew, sst (2 req'd)	1L37954620D
4010	1H6870000AD	35 Lockwasher, Bourdon Tube, steel pl (2 req'd)	1H26722898D
11 Elbow Fitting, Prop. Band, aluminum	PC00000043D	36 Lockwasher, steel pl (2 req'd)	1H26712898D
12 Connecting Link, sst	1L37964101D	37 Machine Screw, Flapper, steel pl	1B27512899D
13 Control Pressure Block, steel pl	PC00000024D	38 Machine Screw, Bourdon Tube steel pl (2 req'd)	1H26772898D
13a O-ring, Control Pressure Block, neoprene (not shown)		39 Socket Cap Screw, sst (2 req'd)	PC00000051D
14 Control Tubing Assembly	PC00000023D	40 Machine Screw, steel pl (4 req'd)	1A33212898D
15 Cover Gasket, nitrile	1J40750643D	41 Machine Screw, steel pl (4 req'd)	14B4995X01D
16 Cover Latch, steel pl	1H28862898D	42 Machine Screw, steel pl (4 req'd)	1V74352898D
17 Cover, aluminum	PC00000011D	43 Machine Screw, steel pl, pressure block (4 req'd) (not shown)	PC00000026D
18 Cross Spring, sst (2 req'd)	1H26603703D	44 Machine Screw, steel pl (9 req'd)	1A5733X001D
19 Dial Screw, steel pl	1J84152898D	45 Mounting Base, aluminum	2H26512501D
20 Dial, sst		46 Mounting Screw for reset valve (not shown)	1H52702898D
0-30 psig	16A7662X01D	47 Nameplate Screw, steel pl (2 req'd)	1C94192898D
0-60 psig	16A7662X02D		
0-100 psig	16A7662X03D		
0-200 psig	16A7662X04D		
0-300 psig	16A7662X05D		
0-600 psig	16A7662X06D		
0-1000 psig	16A7662X07D		
0-1500 psig	16A7662X08D		



Model
4000 Pressure Controller
 Operation, Parts and Instruction Manuals

Parts (cont'd)

Key Description	Part Number
48 Nameplate, sst	PC00000013D
49* Nozzle O-ring, nitrile	1E22260699D
50 Nozzle, Reversing Block, sst	1U63913513D
-under reversing block screw (Key 62)	
-under reversing block (Key 63)	
-under sealing screw (Key 66)	
53 Pipe Plug, steel (not shown)	1A76752466D
54 Pressure Set Arm, steel pl	PC00000012D
55 Proportional Band Valve Assembly	10A9122X03D
56 Relay Manifold Assembly	PC00000056D
57* O-ring, Relay Manifold, nitrile (2 req'd)	PC00000057D
58 Relay Tubing Assembly, sst	1H6861000AD
59 Reset Tubing Ass'y, sst 4010	1H6866000AD
60 Reset Valve Ass'y 4010	10A9129X0AD
61 Retaining Ring, Gauge Glass, sst (2 req'd)	PC00000006D
62 Reversing Block Screw, sst	24A5720X01D
63 Reversing Block, steel pl	26A0975X01D
64 Roll Pin, Door Hinge, sst (req'd)	1H28882899D
65 Rotary Spring, sst	1J42343702D
66 Sealing Screw, sst	14A5721X01D
67 Set Point Adjustment Post, aluminum (not shown)	PC00000001D
68 Sleeve, Delrin	16A0976X01D
69 Spacer, aluminum	1H26594401D
70 Spring Washer, steel pl	PC00000004D
71 Vent Assembly, plastic/sst	Y602-12D
72 Washer, Dial, steel pl	1R98202507D
73 Washer, Cal. Adjuster, steel pl (2 req'd)	1E87302899D

Relay (See Figure 3)

Key Description	Part Number
74* O-ring, Relay Seat Ring, nitrile	PC00000054D
75 Diaphragm Assembly	18A2451X01D
76 Diaphragm Casing Ass'y, aluminum / steel	12B0460X04D
77 Machine Screw, sst (3 req'd)	PC00000055D
78 Machine Screw, steel pl (6 req'd)	1C89692898D
79 O-ring, nitrile (2 req'd)	1D68750699D

80 Washer, Relay Seat, steel pl (3 req'd)	PC00000053D
81 Relay Manifold, aluminum	PC00000049D
82 Relay Spring, steel pl	1C89612701D
83 Reset Plug and Wire Assembly	12B0468X01D
84 Spacer Ring, aluminum	38A3778X01D
85 Seat Ring, sst	PC00000050D
86 Top Diaphragm	1L55560204D
87 Valve Plug, sst	0Y0617X002D
88 Valve Spring, sst	0X08363702D

Mounting (See Figure 7 & 8)

Key Description	Part Number
89 Cap Screw, steel pl (4 req'd) for wall or Panel Mounting	1B84802405D
90 Cap Screw, steel pl (specify qty req'd)	
-5/16 UNC x 1 inch	1A35262405D
-5/16 UNC x 3/4 inch	1A38162405D
91 Cap Screw, steel pl (4 req'd)	1C33332898D
92 Hex Nut, steel pl (4 req'd)	1C33282898D
93 Lockwasher, steel pl (2 req'd)	1C22572898D
94 Machine Screw, steel pl (2 req'd)	1C63922898D
95 Mounting Bracket, actuator casing, steel pl (not shown)	1F40122507D
96 Mounting Bracket, actuator yoke, steel pl (not shown) -Dyna-Flo Model DFC, DFR, and Others	1C22182502D
97 Mounting Bracket, Panel or Wall, steel pl (2 req'd)	1H2892000AD
98 Mounting Bracket, pipestand	3N97572509D
99 Mounting Spacer, steel pl (specify qty req'd)	1F90672409D
100 Pipe Mounting Clamp, steel (2 req'd)	1P42702898D

*** Commonly Replaced Part**



Model
4000 Control Valve
 Operation, Parts and Instruction Manuals

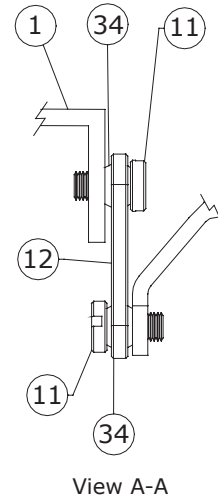
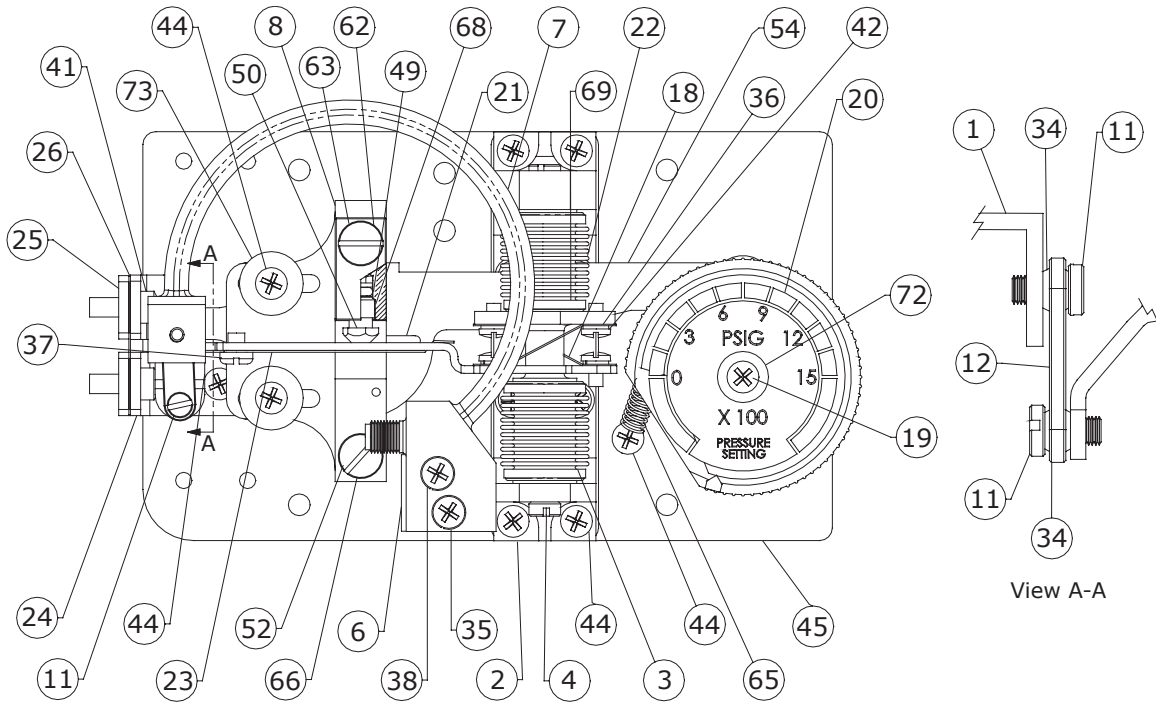
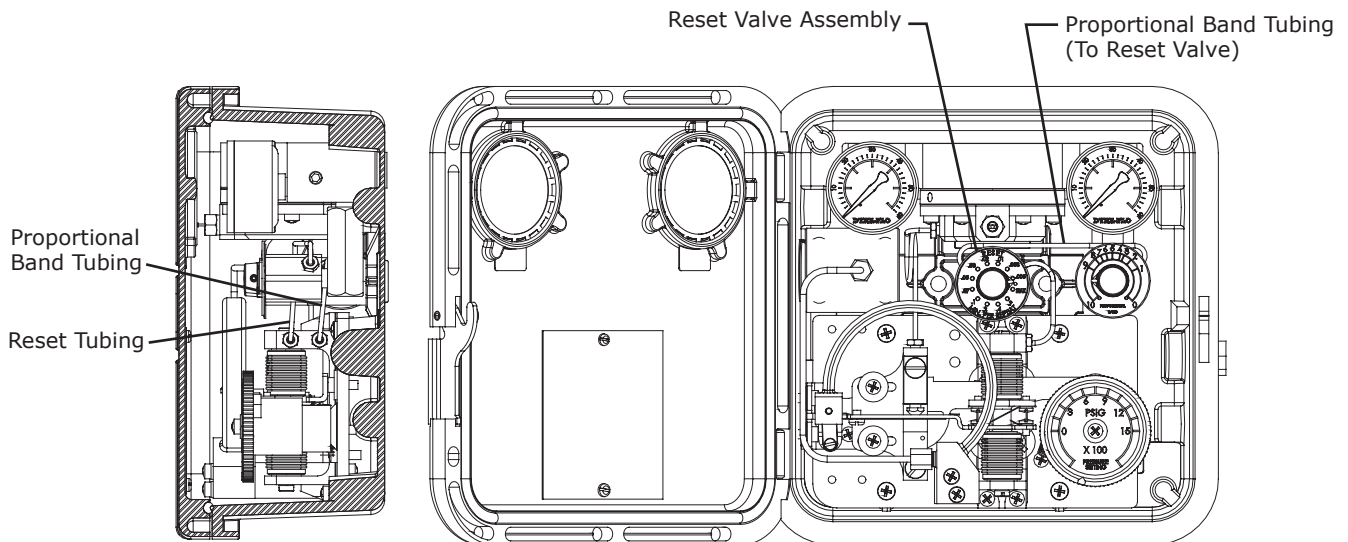

Figure 5 Sub-Assembly Detail

Figure 6 4010 Controller General Arrangement



Not Shown: **Reset Valve Mounting Screw**



Model **4000** Pressure Controller
 Operation, Parts and Instruction Manuals

Figure 12 Model 4000 Mounting Details, Pipestand, Surface Panel

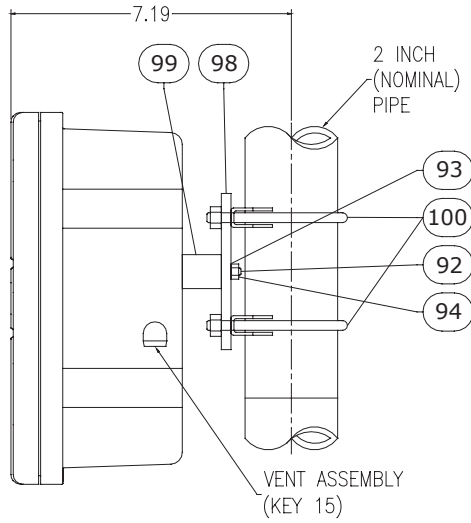

PIPESTAND MOUNTING

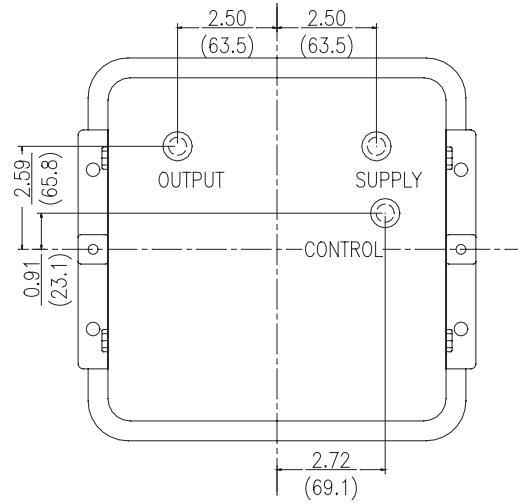

BACK VIEW

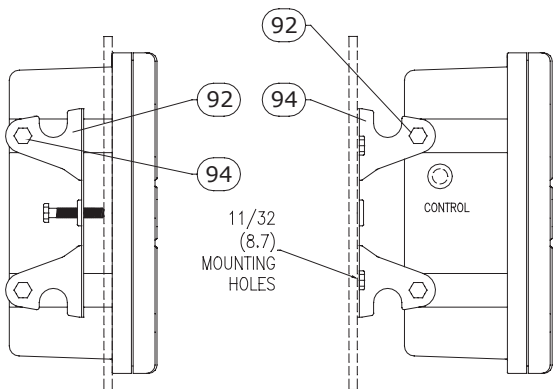

PANEL MOUNTING

WALL MOUNTING

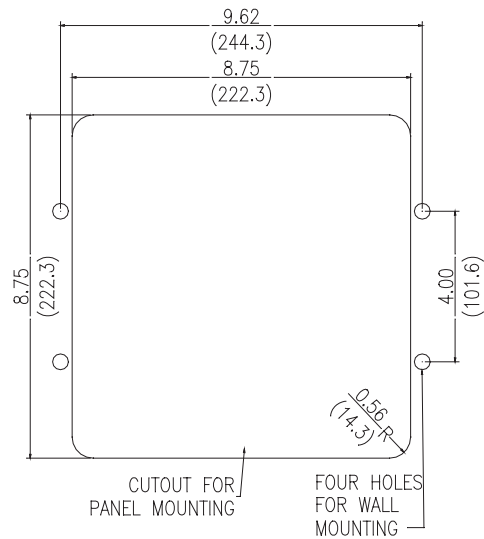

CUTOUT FOR PANEL MOUNTING

FOUR HOLES FOR WALL MOUNTING

INCH
(mm)



Model
4000 Control Valve
Operation, Parts and Instruction Manuals

NOTE

When using yoke style mounting, DON'T PUNCH HOLES in back of case. Use drill.

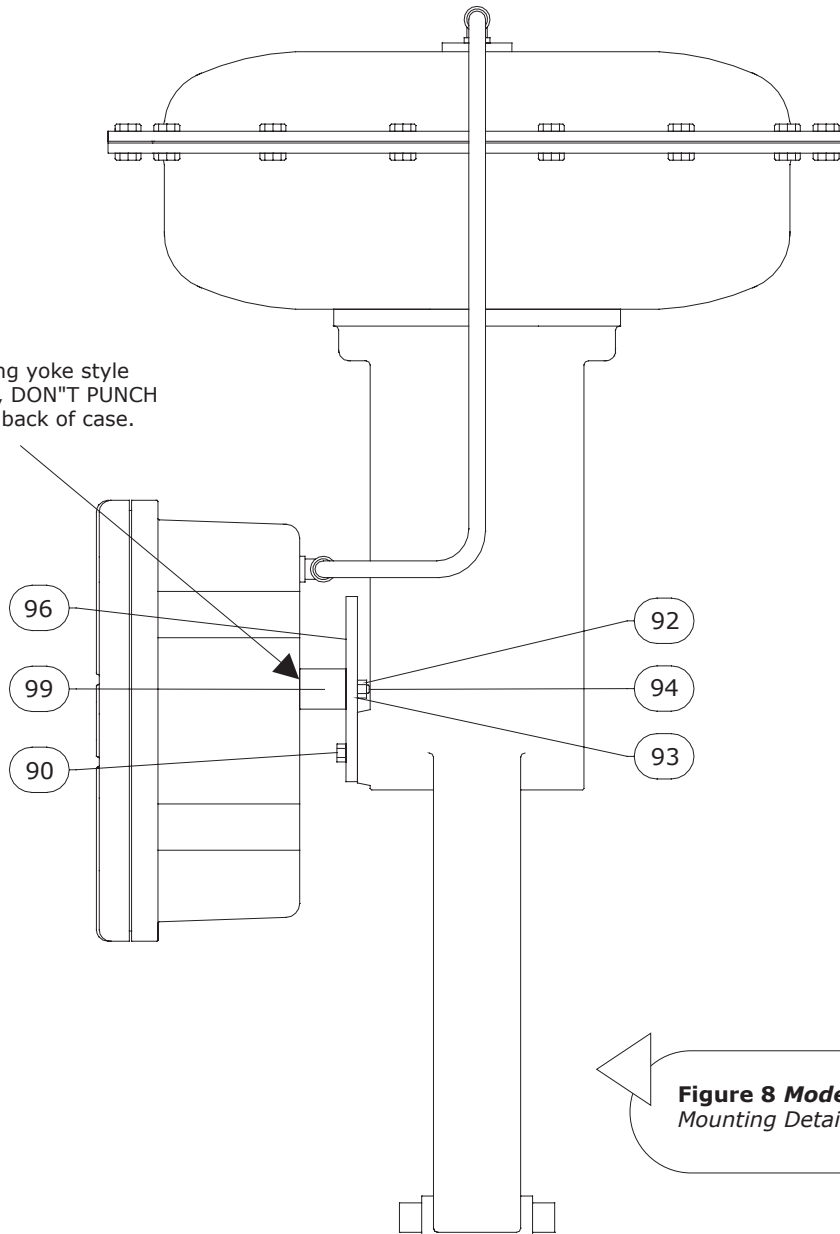

Figure 8 Model 4000
Mounting Details, Actuator Yoke

Our Commitment of Quality

Dyna-Flo is committed to continuous improvement. All efforts have been taken to maximize the accuracy of this information. Without notification, product specifications and designs may be modified at any time. The issue of this document is for information only, and does not imply suitability, a warranty, or guarantee for a specific service.